



Peltier- and Heating-Controller TC3215-RS232

User Manual

Document-Nr: 13062_05
Date: 16. September 2021

CoolTronic GmbH
Untere Sandstrasse 15
CH-5712 Beinwil am See
www.cooltronic.ch

Contents

1. Overview	1
1.1. Application	1
1.2. About the documentation	1
1.3. Items supplied	1
2. Operation and Installation	1
2.1. Overview	1
2.2. Display and operating elements	1
2.3. Inputs and outputs	2
2.3.1. Overview	2
2.3.2. Input Sensor 1	3
2.3.3. Input Sensor 2	4
2.3.4. input Sensor 3	5
2.3.5. Auxiliary Output	5
2.3.6. Auxiliary Input	6
2.3.7. Power output, Peltier-Controller-Mode	7
2.3.8. Power output, Heating-Controller-Mode	7
2.3.9. Fan Control	8
2.3.10. Voltage supply	9
2.3.11. Serial Interface according to RS232C	10
3. Functional description	10
3.1. Overview	10
3.2. Power on	11
3.3. Normal Mode	11
3.4. Set Point Display	11
3.5. Display temperature value of sensor 2	11
3.6. Display temperature value of sensor 2	11
3.7. Programming the configuration values	11
3.8. Display of specific configuration values	13
3.8.1. Set value 1 and 2	13
3.8.2. Tolerance and alarm range	13
3.8.3. Filter	13
3.8.4. Sensor Selection	14
3.8.5. Controller Mode	14
3.8.6. Auxiliary input	14
3.8.7. Auxiliary output	14
3.8.8. Control parameter	15
3.8.9. Temperature offset setting for sensor 1	15
3.8.10. Temperature set-value ramp	15
3.8.11. Limits for sensor 2 and sensor 3	16
3.8.12. Offset for sensor 2 and sensor 3	16
3.8.13. Settings for fan control	16
3.8.14. Settings for dead zone function	17
3.8.15. Supply voltage limits	18
3.9. Host mode	18

3.10. Range error	18
3.11. Error messages	18
3.12. Communication	20
3.12.1. Overview	20
3.12.2. Block format	20
3.12.3. Character set	20
3.12.4. Data flow	20
3.12.5. Debug mode	21
4. Usage with TCCOM for Windows	21
4.1. Warning	21
4.2. Overview	22
4.3. User Interface	22
4.4. Commandline interface	28
4.5. Recorder	28
4.6. Manage configuration	30
4.6.1. Overview	30
4.6.2. Tab "General"	31
4.6.3. Tab "Sensor 1"	34
4.6.4. Tab "Sensor 2"	35
4.6.5. Tab "Sensor 3"	36
5. Command set	38
6. Configuration values	40
7. State codes	41
8. Error codes	41
9. Sensor-Table	42

1. Overview

1.1. Application

The **Peltier- and Heating-Controller TC3215-RS232** is a temperature indicator with controlling function and PWM-output for driving thermoelectric (Peltier) elements.

By simply changing the controller-mode the device can be used as a heating controller. This configures the PWM-output for driving resistive heaters or solid state relays (SSR).

It has a housing for panel mount according to DIN 43700.

It requires an external DC power supply in the range from 12 to 32V and is solely intended for use with a low voltage power supply.

1.2. About the documentation

This documentation is valid for **Peltier- and Heating-Controller TC3215-RS232**, FW-Version V210.34 as of 27.11.2010. The software TCCOM for Windows included in the package is documented in its own manual, supplied with the program. Version V210.34 of the firmware requires TCCOM for Windows V1.81 Build 103 or above.

Most recent versions (as of October 23, 2016) are Firmware V21040 and Software V1.8.3 Build 122.

1.3. Items supplied

Supplied items are:

- Peltier- and Heating-Controller TC3215-RS232
- 2 pcs. mounting clamps
- 2 connectors Sauro CTF, spacing 3.81mm, 8-pole
- this manual as PDF file on CD
- TCCOM for Windows™ on CD
- User manual TCCOM for Windows™ as PDF-document on CD

As an option:

- Interface cable with 9-pole DSUB receptacle and connector Sauro CTF, spacing 3.81mm, 8-pole lengths available: 2m or 5m

2. Operation and Installation

2.1. Overview

The keys are positioned on the visible front of the TC3215-RS232 Peltier- and Heating-Controller. The connections of the instrument are done via three connectors on the rear of the controller and are not accessible after installation. The instrument will be installed via two snap clamps with fastening screws.

2.2. Display and operating elements

The instrument has a 4-digits 7-segment-display. The temperature indication range is -75.0 ... + 175.0. The nominal temperature range is -50.0 ... + 150.0. The unused decimal points are used for displaying the state of the device.

Function of the 3 LEDs:

LED "Heating"	Controller is heating
LED "Cooling"	Controller is cooling
LED "Mode-Display"	Programming mode and other special displays

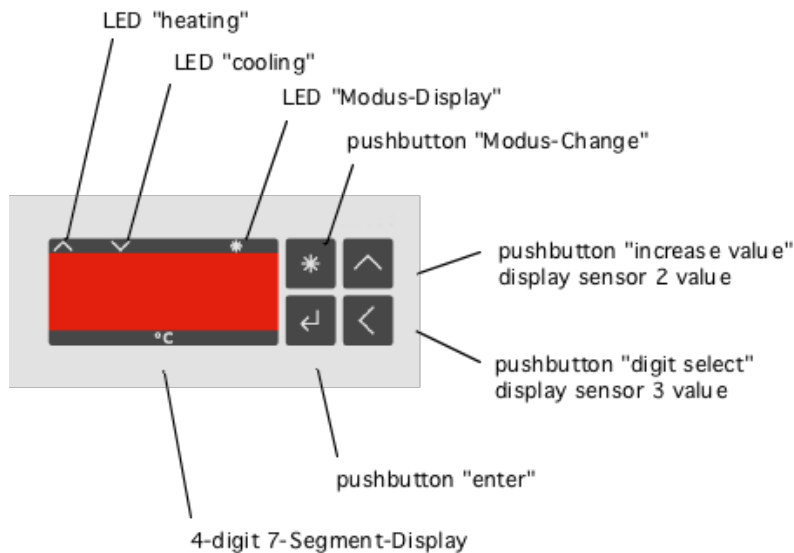

view of the front panel

The 4 Keys have the following function:

Key "Mode-Switch"	changes the operating mode
Key "increase value"	in setup mode: increases the value of the selected digit in normal mode: temporarily displays the value of sensor 2 (if present)
Key "Digit selection"	in setup mode: changes the active digit in normal mode: temporarily displays the value of sensor 3 (if present)
Key "Enter"	stores the value or the item changed

2.3. Inputs and outputs

2.3.1. Overview

The connection is made with three connectors on the rear side of the controller.

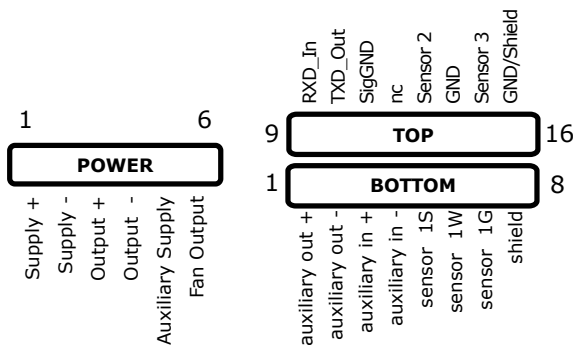

view at the connectors

The connection is made via a 6-pole connector for power supply and power output and two 8-pole plugs for signals and sensors.

Voltage supply and power output

Pin configuration	1	power supply (plus)
	2	power supply (minus)
	3	power output (plus)
	4	power output (minus)
	5	control supply input (plus)
	6	fan output (minus)

Control and sensor connections

Pin configuration	1	Signal output (plus)
	2	Signal output (minus)
	3	Control input (plus)
	4	Control input (minus)
	5	sensor input (Sensor 1)
	6	3-wire input (Sensor 1)
	7	GND (Sensor 1)
	8	GND (optional shield of sensor cable)
	9	RS232, RX-data from personal computer
	10	RS232, TX-data to personal computer
	11	RS232, signal ground
	12	not connected, do not use
	13	input (Sensor 2)
	14	GND (Sensor 2)
	15	input (Sensor 3)
	16	GND (Sensor 3)

2.3.2. Input Sensor 1

The sensor input can be configured for using Pt100, Pt1000 or a user defined sensor (e.g. PTC or NTC).

Input voltage range 100..1100mV nominal

Sensors

- pt100
resistance range apr. 70 .. 167 Ohm (for - 75.0 ... 175.0 °C), sensor current apr. 1.7 mA
- pt1000
resistance range apr. 700 .. 1670 Ohm (for - 75.0 ... 175.0 °C), sensor current apr. 0.7 mA
- Spezial
resistance range and sensor current depends on the custom sensors properties
factory default is pt1000, see above

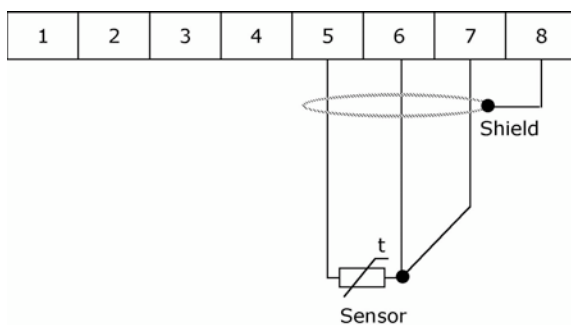

Wiring of a 3-wire sensor

The standard measuring principle is 3-wire technique, where the wire resistance and its changes (within reasonable limits) does not affect the accuracy. Wiring see above.

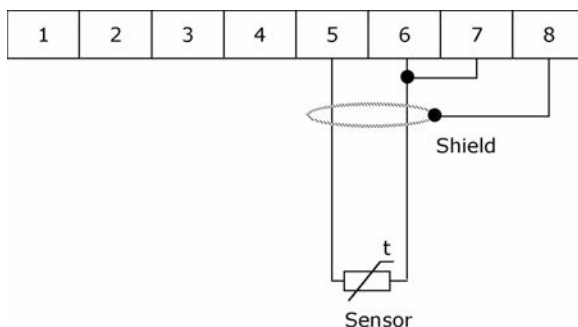

Wiring of a 2-wire sensor

For 2-wire sensors the GND has to be linked with the 3-wire input terminal. The wire resistance will not be compensated, this leads to the following errors:

- permanent shift as a function of the wire resistance resulting a higher temperature value displayed
- variable error as a function of the temperature change of the cable environment with the cable's temperature coefficient

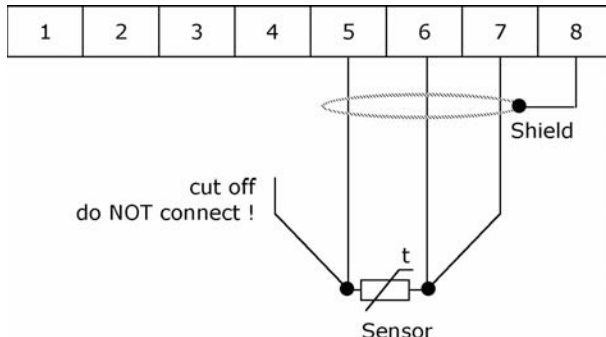

Wiring of a 4-wire sensor

For 4-wire sensors one lead may not be connected in order to maintain equal resistance for the forth and back wire, thus building a 3-wire system. The spare wire should be cut off to avoid picking up noise.

The shielding is for all versions optional, its necessity depends on the conditions of the equipment:

Lead length of the sensor > 1m Shielding recommended in general

pt1000 Shielding recommended in general

Noise occurs, reading disturbed Shielding is necessary

The maximum length of the sensor leads is limited by the resistance of max. 3 Ohms at 25°C for one leg. Dissimilar leads cause measuring errors (e.g. different wire diameters or materials).

Sensor leads with larger cross section than 0.5 mm² or 0.75 mm² reduce the wire resistance and thus reduce measurement errors.

2.3.3. Input Sensor 2

This input is only suitable for pt1000 and provides 2-wire connection only.

Input voltage range 500..1100mV nominal

Sensors pt1000
 resistance range apr. 700 .. 1670 Ohm (for - 75.0 ... 175.0 °C), sensor current apr. 0.7 mA

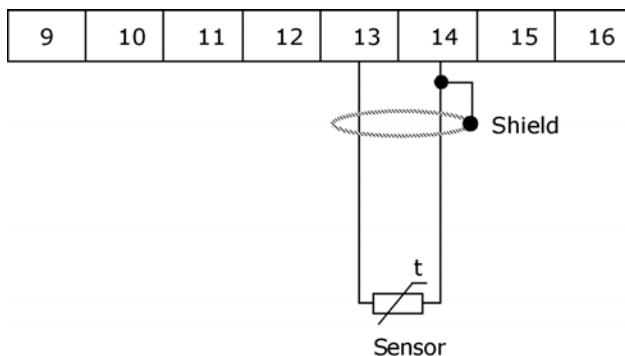

Connecting Sensor 2

Sensor 2 is checked against its temperature limit 2. If the actual temperature exceeds this limit the power output is shut off and error E005 is set.

The value of sensor 2 is used for the dead zone function, refer to chapter "Dead Zone Function".

Configuration of sensor 2

tempLimit2	limit value 0.1 °C -99.9 disables sensor input 2 nnn.n limit value, range -99.9, -75.0 ... + 175.0
offset2	compensation value in 0.1 °C nnn.n value, range -9.9 ... + 9.9

The factory calibration is stored in a linearization table. The default offset-setting is 0.0

2.3.4. input Sensor 3

This input is only suitable for pt1000 and provides 2-wire connection only.

Input voltage range	500..1100mV nominal
Sensors	pt1000 resistance range apr. 700 .. 1670 Ohm (for - 75.0 ... 175.0 °C), sensor current apr. 0.7 mA

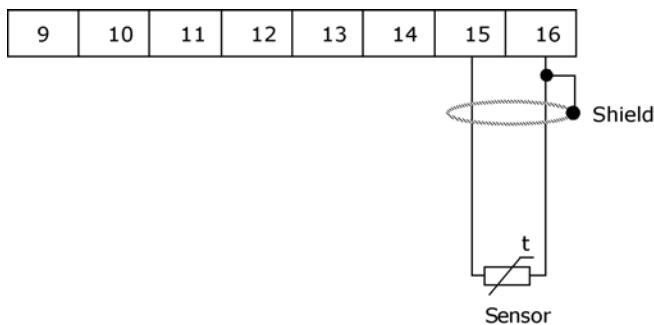

Connecting Sensor 3

Sensor 3 is checked against its temperature limit 3. If the actual temperature exceeds this limit the power output is shut off and error E006 is set.

The value of sensor 3 is used for controlling the fan output, refer to chapter "fan control".

Configuration of sensor 3

tempLimit3	limit value 0.1 °C -99.9 disables sensor input 3 nnn.n limit value, range -99.9, -75.0 ... + 175.0
offset3	compensation value in 0.1 °C nnn.n value, range -9.9 ... + 9.9

The factory calibration is stored in a linearization table. The default offset-setting is 0.0

2.3.5. Auxiliary Output

The instrument has a digital output which serves the signalization of the process status. According to the configuration the output becomes active at:

"OK"-function

- the auxiliary output will be activated if the actual temperature of sensor 1 is in a range +/- tolerance range around the set-value
- using the dead zone function the output will be activated, when the temperature is inside the dead zone with output stage shut off
- the auxiliary output will be inactive, if any error is set

“Alarm”-function

- the auxiliary output will be activated if the actual temperature of sensor 1 is outside +/- alarm range around the set-value
- the auxiliary output will be active, if any error is set

Applicable voltage	max. 30V
Output current	max. 100 mA
Overload protection	limited protection against voltage spikes
Type	NPN-Transistor
Minimum Voltage	< 2V in switched-state

The following diagram shows the connection to a SPS input. A voltage lower than 2 Volts at the SPS-input corresponds to an activated auxiliary output.

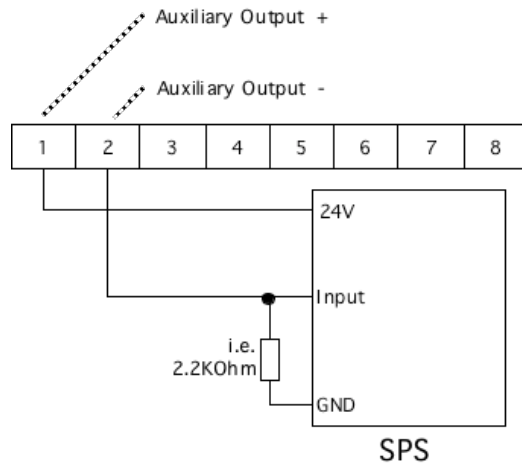

Wiring of a SPS to the auxiliary output (LOW-active)

The following diagram shows the wiring to the a SPS input. A voltage higher than > 22 V at the SPS input corresponds to an activated auxiliary output.

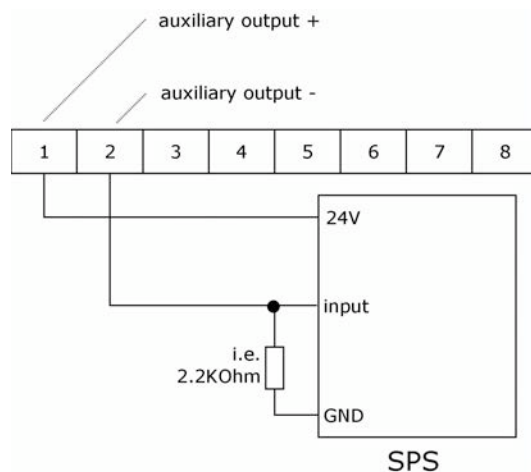

Wiring of a SPS to the auxiliary output (HIGH-active)

2.3.6. Auxiliary Input

The instrument has a digital input, which can be used to switch the power output on or off or select the set-value. Depending on the configuration:

- “OFF”-function, in case of activated input the power output is off (this option is set as default in order to have the device functional without wiring the auxiliary input)
- “ON”-function, the power output is on with input activated
- “DUAL-Mode”-function, the instrument uses set-value 2 with activated input and set-value 1 if inactive or not connected

Maximum input voltage	30V
Input resistance	approx. 1 KOhms
Voltage for „ON“	> 5V
Voltage for “OFF”	< 1V

The input works independently of the polarity. Operation with alternating current is not possible, since the power output would be modulated.

The following diagram shows the driving by a NPN-output of a SPS. When the NPN output is on (= LOW) the auxiliary input will be activated.

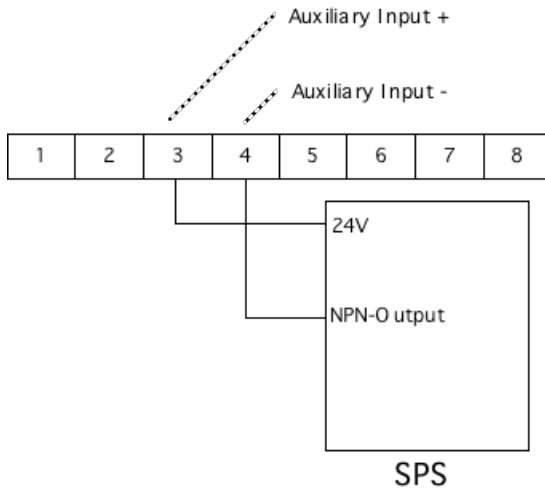

Wiring of a SPS to the auxiliary Input

2.3.7. Power output, Peltier-Controller-Mode

The power output provides a pulse width modulated signal whose polarity is changed automatically to switch from heating to cooling or vice versa.

Output voltage	depending on the supply voltage,
Output current	typically value is supply voltage minus 0.5 .. 1.0V
PWM frequency	15 A max. continuously, 19A for < 60 seconds
Overload protection	around 4.5 kHz
Connecting cable	Over current shut off with automatic retry
	recommended cross section 0.75 ...2.5 mm ² depending on the Peltier current and lead length

The marking “Output +” and “Output -” refer to the polarity when cooling down. If the system cools when it should heat and vice versa, please exchange the connections

Regarding the EMV compatibility (radiated interference) it is recommended to use twisted wires, especially in case of long cable length.

2.3.8. Power output, Heating-Controller-Mode

The power output provides a pulse width modulated signal to be used with resistive heaters or solid state relay.

Output voltage	depending on the supply voltage,
Output current	typically value is supply voltage minus 0.5 .. 1.0V
PWM frequency	15 A max. continuously, 19A for < 60 seconds
Overload protection	around 4.5 kHz (use with resistive heater connected to the output directly)
Connecting cable	around 3Hz for use with solid state relay
	Over current shut off with automatic retry
	recommended cross section 0.75 ...2.5 mm ² depending on the Peltier current and lead length

The marking “Output +” and “Output -” refer to the polarity when heating !

If the actual temperature is higher than the set value the output is shut off.

For use with solid state relay the parameter „pwm-limit“ has to be configured to 1. This activates a slow pwm control scheme with around 3 Hz switching frequency and 16 steps, well suited for solid state relay with zero crossing switch mode.

Regarding the EMV compatibility (radiated interference) it is recommended to use twisted wires, especially in case of long cable length.

2.3.9. Fan Control

The controller TC3215-RS232 has an open drain MOSFET output to switch the warm side fan of the thermoelectric assembly.

At present the fan is switched on and off according to the limit and hysteresis settings and the value measured with sensor 3. The limit value for sensor 3 must be set to a suitable value to enable this function.

If the temperature at sensor 3 exceeds the limit value the output stage is shut off, error E006 is set, but the fan output remains active.

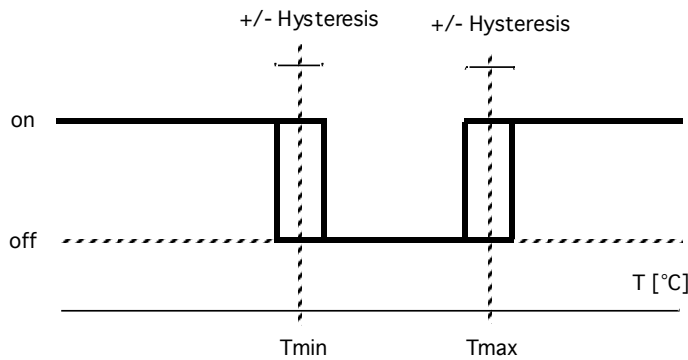

Output voltage	depends on wiring, max. 40V
Output current	max. 1.5 A
Overload protection	PTC-fuse
Connecting cable	recommended cross section 0.75 mm ²

The terminal “Fan” is the negative pole of the fan. Typically the positive pole of the fan is connected to the positive supply („Supply+“) of the controller.

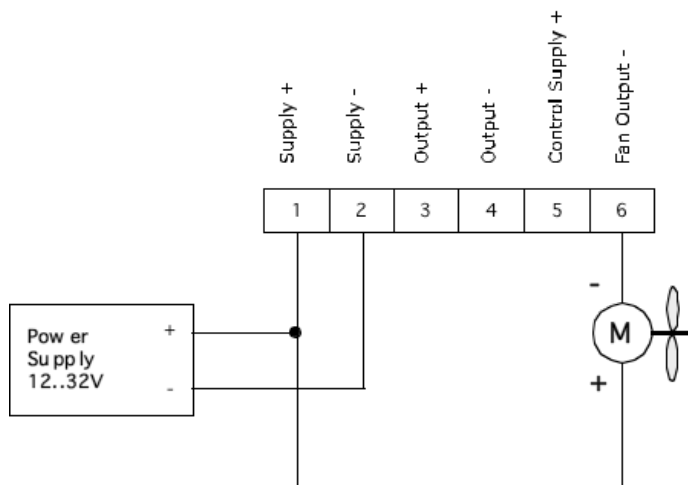

Diagram: typical application, fan supplied by same supply as controller

The user is free to apply any voltage in the allowed range to comply with the requirements of the fan used.

The negative pole of the fan supply must then be connected to the negative pole of the controller supply („Supply-“).

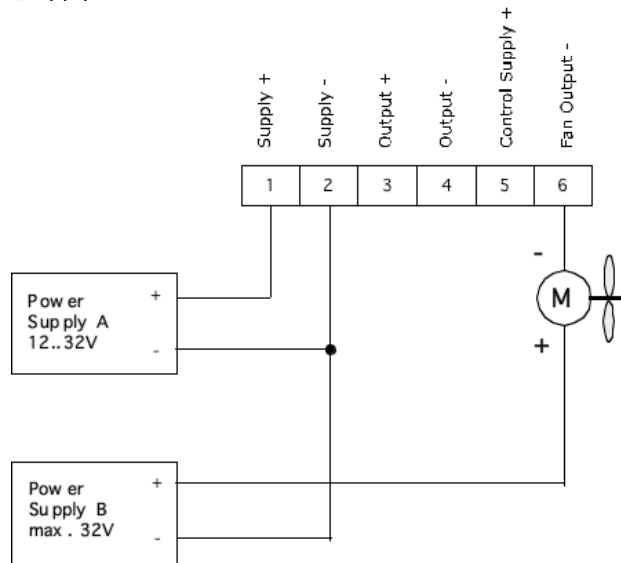

Diagram: fan supply different from controller supply

2.3.10. Voltage supply

The standard version has the controller supply internally connected to the supply + terminal. Both voltages are therefore equal.

Voltage supply 12.. 32V Direct Current
 Current consumption ca. 100 mA plus output current, overall 19 A max.

Protection internal 15A fast acting fuse
 (may only be replaced by the manufacturer – the warranty is cancelled after opening of the case)

Supply cable recommended cross section 0.75... 2.5 mm² depending on the peltier current and lead length

Regarding the EMV compatibility (radiation influence) it is recommended to use twisted leads, especially in case of long lead length.

With the option –SCS (= separate controller supply) the supply of the controller is separated from the supply of the output stage. This allows to use the device with loads specified for operating voltages lower than 12V.

Controller

Voltage supply 12.. 32V Direct Current (voltage supply B)
 Current consumption ca. 100 mA
 Protection internal 0.8A fast acting fuse
 (may only be replaced by the manufacturer – the warranty is cancelled after opening of the case)

Supply cable recommended cross section 0.5 mm² min.

Output stage

Voltage supply 1.0.. 32V Direct Current (voltage supply A)
Note: configure limits for supply-voltage-monitoring accordingly

Current consumption apr. equal to output current, overall 19 A max.
 Protection internal 15A fast acting fuse
 (may only be replaced by the manufacturer – the warranty is cancelled after opening of the case)

Supply cable recommended cross section 0.75... 2.5 mm² depending on the peltier current and lead length

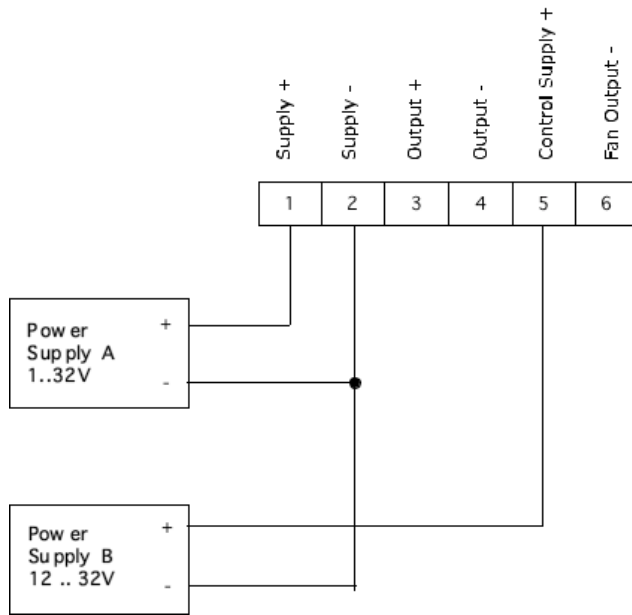

Diagram: Wiring with output supply separate from controller supply

2.3.11. Serial Interface according to RS232C

The optional serial interface supports a simple protocol with software handshake, using signals RXD and TXD only.

The interface is used for factory internal adjustments and diagnostics.

It can be used by the customers for remote control e.g. by a master process control unit. In this case CoolTronic can not be made liable for correct function of the device and the resulting accuracy.

The interface has the following data configuration

Data configuration	8 Data-, 2 Stop-Bits
Parity	none
Baudrate	9600 Baud

The interface signals are connected to one of the 8-pole connectors.

9	RS232, RX-data from personal computer
10	RS232, TX-data to personal computer
11	RS232, signal ground

Ready to use cables with 2m or 5m length may be ordered as accessories.

The calibration of the instrument is part of the configuration data. Therefore it is not allowed to exchange the configuration data between individual instruments.

3. Functional description

3.1. Overview

The device has two basic modes, the normal mode and the configuration mode. After power on the controller starts in the normal mode.

Pressing the „Mode Switch“ button shortly displays the actual set value. In dual mode this is the active set-value, i.e. the value selected with the auxiliary input.

Pressing the „Mode Switch“ button for long will switch the controller into the configuration mode.

3.2. Power on

Immediately after power on the controller shows a test display (all segments and decimal points are illuminated). The device tries to read out a valid configuration from the EEPROM. If this fails, the device shows the error message E100 and is not operational. In case of an E100 error please contact the factory.

The outputs are inactive during the initialization process of the device and if errors are detected.

3.3. Normal Mode

In the normal mode the temperature will be measured and displayed continuously. The "mode select" button is continuously checked. The controller processes the actual temperature and the set temperature and calculates the power output setting.

The LED "heating" and LED "cooling" are flashing, if the temperature is outside the alarm range.

The LED "heating" and LED "cooling" are on, if the temperature is between the tolerance- and alarm range.

The LED "heating" and LED "cooling" are off, if the temperature is within the tolerance range.

Using the dead zone function both LED's are on, if the temperature is inside the dead zone.

3.4. Set Point Display

To display the set point value press the „mode select“ button, until the "mode display"-LED starts to flash. Now release the button. The controller will show the set value for 3 seconds. After that the instrument automatically returns to display the actual temperature of sensor 1.

3.5. Display temperature value of sensor 2

To display the temperature value of Sensor 2 press the „increase value“ button. The controller will show the value for 3 seconds. After that the instrument automatically returns to display the actual temperature of sensor 1.

If Sensor 2 is not enabled, this function is inhibited, the button does not react at all.

3.6. Display temperature value of sensor 2

To display the temperature value of Sensor 3 press the „digit select“ button. The controller will show the value for 3 seconds. After that the instrument automatically returns to display the actual temperature of sensor 1.

If Sensor 3 is not enabled, this function is inhibited, the button does not react at all.

3.7. Programming the configuration values

To program the configuration values press the „mode select“ button, until the "mode display" starts to flash and continue to hold it down until the controller changes to configuration mode.

Please note, that not all internal values can be programmed using the buttons. Certain values can only be adjusted via the serial interface. In this chapter only the values changeable via the buttons are described.

The following description uses the these conventions:

bold:	Segment flashing
normal	Segment consistent on
grey	Segment off

Step 1 – Switch to the configuration mode

Press button „mode select“
The LED „mode-display“ starts to flash

Keep pressing till the display changes to:

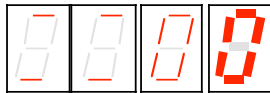

- the 2 most left digits show 2 horizontal lines to indicate that the kind of value can be selected
- the left most digit is blinking and can be changed
- the LED "heating" and LED "cooling" furthermore indicate the state of the controller
- a timeout is running, which returns to the normal mode, if no button is pressed

Step 2 – Selection of the value to be changed

There are the following options:

- press button „enter“ to display the selected parameter
- press button "increase value" or button „digit selection“ to select a different parameter
- press button "mode select" to exit the configuration mode immediately

Step 3 – adjust value

- You have selected the kind of value with the button „increase value“, "digit select" and the button "enter"
- the display jumped to display the value selected, in this example the set temperature:

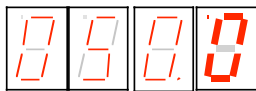

- the set temperature is displayed (here for instance 50.0°C)
- the last digit flashes

there are the following options:

- press button „increase value“ to change the flashing digit (0..9, 0..)
- press button "digit select" to choose another digit

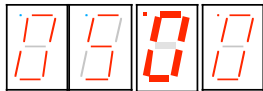

- adjust the desired value using the buttons „increase value“ and „digit select“

Step 4 – confirm or reject value

- press button „enter“ to confirm the adjusted value
- all digits flash
- after releasing the „enter“ button the value has been transferred to the non volatile memory
- the display indicates again, which value can be changed, see step 2

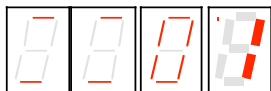

- to reject the value - press button „mode select“ to exit immediately the configuration mode without changing the actual value

Please note, that changed values get effective by leaving the setup mode.

During configuration mode all outputs are inhibited to avoid undesirable effects, which may be caused by uncompleted new settings.

Display of the 2 leftmost digits and their meaning

Display	Meaning
00	Set value 1
01	Set value 2
02	tolerance range
03	alarm range
04	filter-time constant
05	Sensor selection
06	controller mode
07	function of auxiliary input
08	function of auxiliary output
09	P
10	I
11	D
12	IL
13	PWM-Limit
14	temperature correction, sensor 1
15	temperature ramp of the set value
16	temperature limit, sensor 2
17	temperature limit, sensor 3
18	temperature correction, sensor 2
19	temperature correction, sensor 3
20	lower temperature threshold of fan control
21	upper temperature threshold of fan control
22	hysteresis of fan control
23	time delay of fan control
24	lower limit of supply voltage
25	upper limit of supply voltage
26	lower temperature threshold of dead zone function
27	upper temperature threshold of dead zone function
28	hysteresis of dead zone function

All values are checked for an internally defined value range. If the range is exceeded the value is reset to a start value and must be adjusted again.

If some value was out of range the value will be reset to a default value when selected.

Value range, start value and default value are documented in chapter "Configuration vales".

3.8. Display of specific configuration values

3.8.1. Set value 1 and 2

The adjustable range is -75.0 ... 175.0, whereas the nominal range is -50.0 ... 150.0. Hence the highest digit changes only 0 .. 1 .. - (negative sign).

3.8.2. Tolerance and alarm range

- the range is 0.0 .. 9.9
- the display is in 1/10°

3.8.3. Filter

- visualized by „F“ for Filter in the left most digit



- Digit 0 und 1 show the time constant in seconds 1 - 2 - 5 - 10 - 20 - 50

3.8.4. Sensor Selection

Display „Sn“ for sensor und the identification number 0 - 1 - 2 for Pt100 / Pt1000 and special

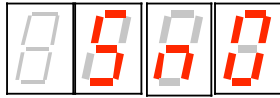

3.8.5. Controller Mode

Display “PEL” for Peltier-Controller-Mode and „HEA“ for Heating-Controller-Mode

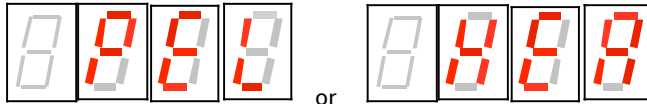

3.8.6. Auxiliary input

The auxiliary input can optionally be used for switching the power output ON or OFF. Switching OFF is standard, to have the device functional without external wiring. In addition the input may be configured to select the set value.

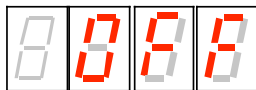

Display „OFF“ corresponds to the switch OFF Function, where the the controller output will be switched off when activated.

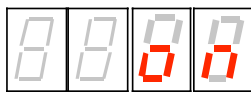

Display „on“ corresponds to the switch ON Function, where the the controller output will be switched on when activated.

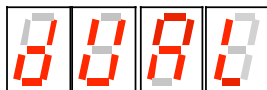

Display “dUAL” enables the “Dual mode”. With the auxiliary input activated set value 2 is effective, else set value 1.

3.8.7. Auxiliary output

The auxiliary output has two operation modes:

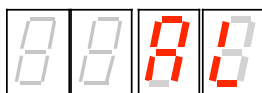

- “AL” corresponds to the Alarm-Function: the output is activated, if the temperature is outside the alarm range

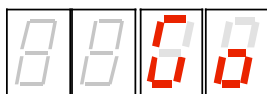

- “Go” corresponds to the Good-Function: the output is activated, if the temperature is inside the tolerance range

3.8.8. Control parameter

The Parameter adjustment shows an identification letter in the first digit: (in the example a "P" for the proportional coefficient KP):

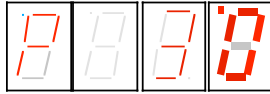

Meaning of the identification letter:

- P: Control Parameter KP
- I: Control Parameter KI
- d: Control Parameter KD

The maximum value is 63, in case of exceeding the value the display returns to Zero and it must be set again from start. A value of 0 inhibits the corresponding part of the control algorithm

- L: Control Parameter IL (Integration limit), maximum value 999, a value of 0 inhibits the integral part, the value is multiplied internally by ten
- C: PWM-Limit (C = "C"utoff), value range 0..127, in case of exceeding the value the display returns to Zero and it must be set again from start. PWM-Limit Zero in fact switches off the power output

Heating-Controller-Mode:

PWM-Limit = 1 activates the slow PWM-mode for use with solid state relay (SSR, apr. 3 Hz, 16 steps)

3.8.9. Temperature offset setting for sensor 1

The left most digit shows the identification letter „o“:

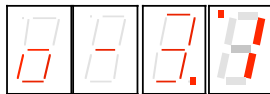

To correct errors caused by temperature sensor or wiring, an offset of -9.90 to 9.9 can be input. Use a reference thermometer or an ice bath for calibration.

3.8.10. Temperature set-value ramp

The left most digit shows the identification letter „r“:



The ramp value in 0.1°C is displayed, in our example 3.0°C. The value range is 0.0 to 9.9.

A value of 3.0 means, that the internal set point value will be increased linearly with a rate of 3.0°C per minute

A selected value of 0.0 inhibits the ramp function, any change of the set point will become effective immediately.

The „nominal set point value“ is the value, which appears after short pressing the mode button.

The “actual set point value“ is an internal value, which will be evaluated based on the ramp adjustment and nominal set point value, as well as on the prehistory.

When you turn on the controller the ramp starts at the actual temperature, the actual set point temperature is set to that value. In all other cases the starting point is the actual (internal) set point temperature.

3.8.11. Limits for sensor 2 and sensor 3

The adjustable range is $-75.0 \dots 175.0$, whereas the nominal range is $-50.0 \dots 150.0$. Hence the highest digit changes only 0 .. 1 .. - (negative sign).

A value of -99.9 disables the corresponding sensor. Adjust to -99.9 , if no sensor is connected to avoid an error message caused by an open input.

The range $-99.8 \dots -75.0$ is not allowed !

3.8.12. Offset for sensor 2 and sensor 3

The left most digit will show 2 or 3 horizontal lines:

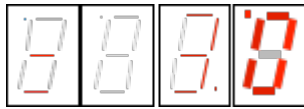

Sensor 2, 3.0°C

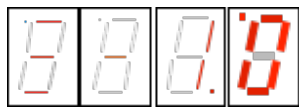

Sensor 3, -1.0°C

To correct errors caused by temperature sensor or wiring, an offset of -9.9 to 9.9 can be set. Use a reference thermometer or an ice bath for calibration.

If starting from 00.0 the negative sign is set, the value jumps to -0.1 , because -0.0 is a useless value.

3.8.13. Settings for fan control

The upper and lower switch point can be set in the range $-75.0 \dots 175.0$. Hence the highest digit changes only 0 .. 1 .. - (negative sign).

When setting the hysteresis value the left most digit will show "H":

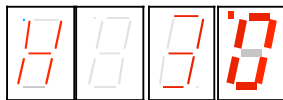

The value range is 0.0 bis 9.9 where a small value will cause unnecessary frequent on / off cycles which is not recommended because this will reduce the life expectancy of the fan.

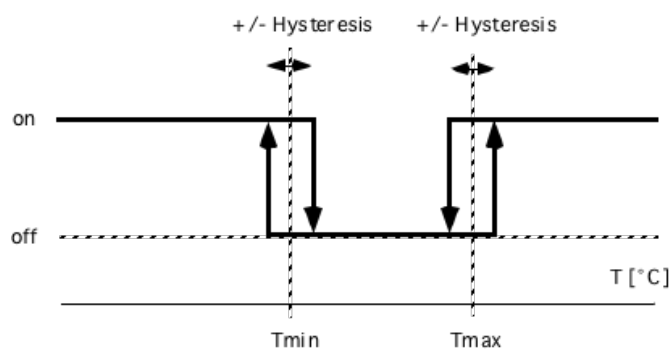

In addition to switch points and hysteresis the behavior of the fan control is influenced by the delay time, which delays switching after the condition for a state change occurs. Value range 0..120 in units of [250ms]:

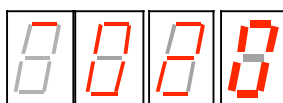

3.8.14. Settings for dead zone function

The upper and lower switch point can be set in the range $-75.0 \dots 175.0$. Hence the highest digit changes only 0 .. 1 .. - (negative sign).

If one or both switch point values are set to -99.9 the dead zone function is inhibited.

The range $-99.8 \dots -75.0$ is not allowed !

When setting the hysteresis value the left most digit will show "H":

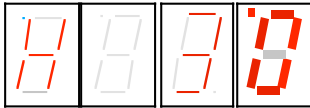

The value range is 0.0 bis 9.9 where a small value will cause unnecessary frequent on / off cycles which is not recommended.

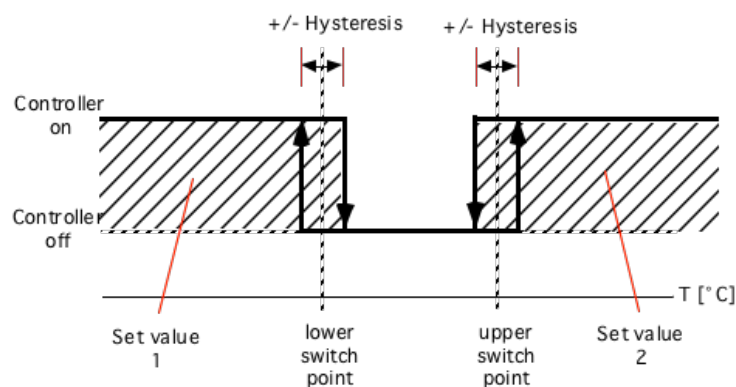

Using the value of sensor 2 the controller of the output stage is switched on and off according to the switch points and the hysteresis value as shown in the diagram above.

Behavior at the lower switch point

- if the value of sensor 2 goes below lower switch point minus hysteresis value, controller and output stage are switched on. The control loop works with set value 1
- if the value of sensor 2 goes above lower switch point plus hysteresis value, controller and output stage are switched off

Behavior in the zone between both switch points

- controller and output stage are off

Behavior at the upper switch point

- if the value of sensor 2 goes above upper switch point plus hysteresis value, controller and output stage are switched on. The control loop works with set value 2
- if the value of sensor 2 goes below lower switch point minus hysteresis value, controller and output stage are switched off

If dual-mode is activated the set value is selected by the auxiliary input and NOT by the dead zone function !

The fan control is independent from the dead zone function to make sure that the warm side of the peltier system is cooled if necessary.

3.8.15. Supply voltage limits

The voltage of the power supply of the output stage is supervised. The user may configure a lower and upper limit. If the voltage is outside this range the output stage is switched off.

With the SCS-option (separate controller supply) the supply voltage of the controller is not monitored. Below around 11V the output stage is shut down by an under voltage lockout, but there is no error set under this condition.

Range for the lower limit is 1.0 .. 31.5V, Range for the upper limit is 1.5 .. 32V.

Monitoring the supply voltage does not protect against damages caused by excessive supply voltage values. Applying more than 33V may destroy the device !

3.9. Host mode

When the controller receives characters via the serial interface, they are decoded and if a valid command is recognized, it is executed immediately. The device in parallel processes and displays the sensor values and performs the control algorithm.

There is no visualization on the display during the interface access. Values changed in the internal data-structure will be used immediately. Values changed in the EEPROM will only become effective, when the command u_0_0 is sent. This happens automatically by using the program TCCOM for Windows. In case of using your own control program the procedure described above has to be implemented.

In case of uncertainty whether all values have been updated, it is recommended to turn off and on the controller, after altering the configuration !

The calibration is part of the configuration data and unique for each controller. Therefore it is not allowed to exchange data sets between different controllers.

3.10. Range error

If the actual value falls below -75.0°C or exceeds $+175^{\circ}\text{C}$, the controller will enter a temporary error status. The display shows a flashing "9999". The power output is switched off. The instrument checks continuously the measuring value. If the value returns within the allowed limits, the controller returns automatically to normal operation.

Please note, that only in the range of $-50.0 \dots + 150.0^{\circ}\text{C}$ the accuracy of the measurement is guaranteed.

3.11. Error messages

A non fatal error will be displayed as „Ennn“ for 5 Seconds after its detection, then the controller returns to normal operation. If the error is still present, it is displayed again immediately.

Fatal errors will be displayed permanently. They can only be reset by switching the device off and on.

Error Number	Meaning	Error cause – and removal
<u>Non fatal error</u>		
E001	General error	several causes > contact factory
E002	Error of writing the EEPROM	The writing of the configuration value has failed > repeat configuration-step > contact factory

Error Number	Meaning	Error cause – and removal
E003	over-current error	Short circuit at the output, Peltier module defect > check wiring / correction > check Peltier module / replace > if permanent contact factory
E004	controller overheated	temperature inside of the controller is too high, ambient temperature too high, Instrument exposed directly to the sun, output overloaded > avoid excessive external warming > eliminate overload > eventually try to reduce PWM-Limit usually this error disappears because the controller cools down with output stage shut off. If the the reason persists, the device performs some sort of cycling between normal operation and E004 error. To avoid damages, fatal error E400 will be set after a certain number of cycles
E005	sensor 2 value beyond limit	temperature of sensor 2 higher than configured limit
E006	sensor 3 value beyond limit	temperature of sensor 3 higher than configured limit
E007	sensor 2 value out of range	temperature of sensor 2 < -75.0 or > 175.0°C no sensor present or wiring incorrect if sensor 2 is not present, disable input by setting the limit to -99.9 to avoid this error
E008	sensor 3 value out of range	temperature of sensor 3 < -75.0 or > 175.0°C no sensor present or wiring incorrect if sensor 3 is not present, disable input by setting the limit to -99.9 to avoid this error
E009	Watchdog error	interference or software error > one time appearance may be ignored > else contact factory
<u>Fatal error</u>		
E100	EEPROM contains no valid configuration	power supply failure during prior configuration change, unsuitable TCCOM version, invalid commands or parameter values used > Switch off / switch on to reset fatal error > re-configure > contact factory
E200	Stack error	excessive electronic noise or program failure > Switch off / switch on to reset fatal error > one time appearance to be ignored > else contact factory
E400	permanent overheating	controller overheated several times since power up > Switch off / switch on to reset fatal error > eliminate cause for overheating (see E004) > contact factory

3.12. Communication

3.12.1. Overview

The information below will be required for the implementation of own Control-Software. Otherwise you can ignore them.

Warning: wrong usage of the commands shown here can render the controller useless, can destroy the controller and the system attached. High temperature and high currents can occur. Danger of injuries and fire hazard !

3.12.2. Block format

Communication uses a simple ASCII-Protocol. To simplify the use of the serial communication the program "TCCOM.EXE" has been developed. It is included with the RS232 option.

It is also possible to use a simple Terminal-Program even it's less comfortable.

Synchronization	*
Command (Master only)	<address> _ <command> _ <parameter> _ <value>§
Acknowledge (Slave only)	. / ? / #
Response (Slave only)	<value> §

The several components are defined as follows:

address	A..Z (at present only A)
command	a..z (used: d, r, u, w)
parameter	0..65535 (no leading zeros, negative figures will be transferred as positive figures, and then interpreted accordingly - "type-casted")
value	0..65535 (no leading zeros, negative figures will be transferred as positive figures, and then interpreted accordingly "type-casted")

3.12.3. Character set

*	Reset communication (from Master to re-synchronize)
A..Z	Address
a..z	commands
_	(underline) is separation character between values
§	End of the message (hex 0x15 or decimal 21 !)
.	acknowledge "OK"
?	acknowledge "unknown / incomplete command sequence"
#	Internal fault

3.12.4. Data flow

Each communication is initiated by the Master (PC), by sending a "*" as synchronization. Hence the Slave (TC3215-RS232) changes to the basic communication state.

Now the Master sends address and command (in our example „A_r_0_0“). After each character, the received character is returned by the Slave (echo). It is very important to check for the echo before sending the next character by the master. Sending the whole command as a string at once will fail !

Finally [15] (hex value) represents the end of the message "§".

Now the Slave executes the command. In case of success it sends a ".". In case of a command the communication is finished. If it was a request, the answer (in our example "65394§") is appended. [15] represents the end of the answer string "§".

Excerpt from a Log file (bold font corresponds to data traffic, normal "High level"-Information, special character are given as hex value in []):

```
15:46 29.07.02001 15:46 TCCOM for Windows
15:46 -----> r_50_0
15:46 > A_r_50_0
15:46 > *A
15:46 < A
15:46 > _
15:46 < _
15:46 > r
15:46 < r
15:46 > _
15:46 < _
15:46 > 5
15:46 < 5
15:46 > 0
15:46 < 0
15:46 > _
15:46 < _
15:46 > 0
15:46 < 0
15:46 > [15]
15:46 < [15]
15:46 < .
15:46 < . (OK)
15:46 < 65394[15]
15:46 < 65394
15:46 -----< -142
```

3.12.5. Debug mode

Initiated with the command d_1_0 the TC3215-RS232 starts to send internal values continuously until the reception of the command d_0_0.

The values sent are recorded by the program TCCOM and can be displayed in graphical form using the function "Recorder".

4. Usage with TCCOM for Windows

4.1. Warning

The program allows extensive changes of internal parameters. Misuse of the program may render the attached controller unusable.

Components attached to the controller or the controller itself may be destroyed. Risk of excessive currents and temperature. Risk of Fire hazard and Injuries !

Therefore it is mandatory to read and understand the manual prior to using the program. Please also consult the manual accompanying the controller and other components of the system. Be sure to understand what you are doing, before using the program

In case of unexpected effects or any uncertainty disconnect the system from power supply and consult the manufacturer or his sales representative.

CoolTronic GmbH cannot be made liable for any damages caused by the use of the program.

4.2. Overview

This documentation applies for TCCOM for Windows version V1.8.1 Build 103 or higher. Only the function specific for TC3215-RS232 are described here.

Concerning all other functions of the program refer to the software manual. General knowledge and experience with Windows™ programs is required.

The Menu “TC3212” provides the standard operation options for the controller TC3215, TC3215 and TC3224 and allows the configuration of most internal values. The factory defined linearization table and other factory setup values are not accessible, therefore are not allowed to be changed.

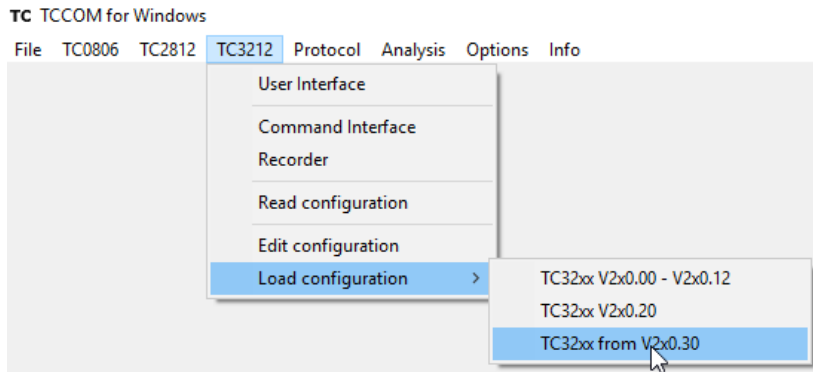

Menu TC3215 with expert mode activated

The above picture shows the available commands with expert mode activated. In normal mode some commands are not available.

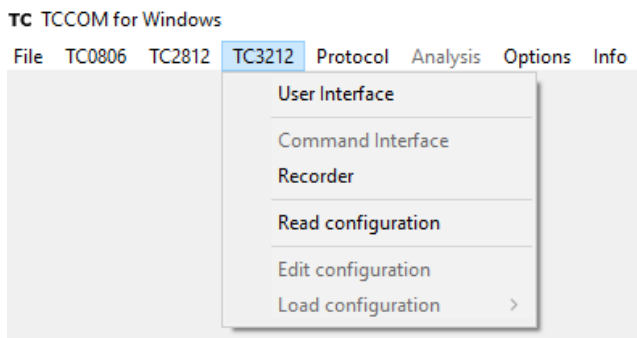

Menu TC3212 in normal mode

4.3. User Interface

The user Interface allows the setting of all parameters of the TC3215-RS232 needed for normal operation.

Observe warnings given in chapter 4.1

Item	Description
<u>Basic settings</u>	
Temperature set value 1 + 2	temperature set points for the controller, range -50.0 ... + 150.0°C, sensor 1 is used for the control loop !
Temperature ramp	speed of change of the temperature set value, range 0.0 .. 9.9°C / Minute. a setting of 0.0 disables the linear ramp function

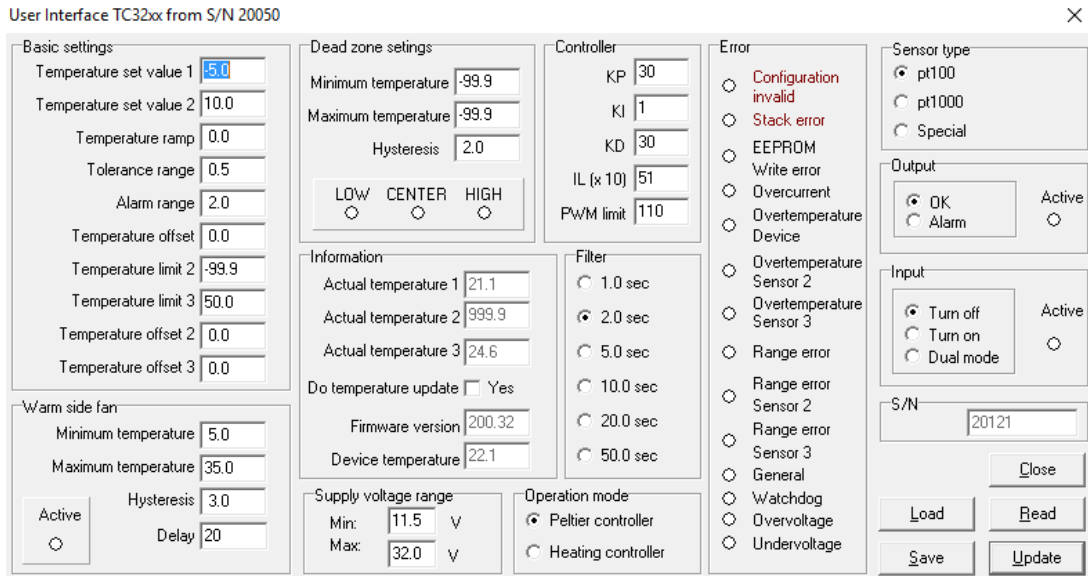

User interface

Item	Description
Tolerance range	<p>defines a range around the set value in between the set value is regarded as reached. If in range:</p> <ul style="list-style-type: none"> - both LED's „heating“ and „cooling“ will be shut off - the auxiliary output will be active if option „OK“ is configured
Alarm range	<p>defines a range around the set value outside which the temperature is regarded as critical. If out of range:</p> <ul style="list-style-type: none"> - LED „heating“ or „cooling“ will blink - the auxiliary output will be active if option „ALARM“ is configured
Temperature offset	value to compensate errors caused by sensor 1 itself or the system setup
Temperature limit 2 / 3	<p>Temperature limit for sensor 2 and 3, range allowed: -99.0, -75.0 ... 175.0, nominal range: -50.0 ... 150.0</p> <p>A value of -99.9 disables the sensor and therefore has to be set if the sensor is absent</p> <p>if the actual temperature value exceeds the limit value the controller output stage will be shut off</p>
Temperature offset 2 / 3	<p>value to compensate errors caused by sensor 1 itself or the system setup</p> <p>The factory setting refers to a resistor 1000 Ohm +/- 0.1% directly connected to the connector</p>
<u>Warm side Fan</u>	
Minimum temperature	lower switch point for the fan (Tmin)
Maximum temperature	upper switch point for the fan (Tmax)
Hysteresis	Hysteresis, explained below ..
Delay	time value, delays switching after the condition for a state change occurs

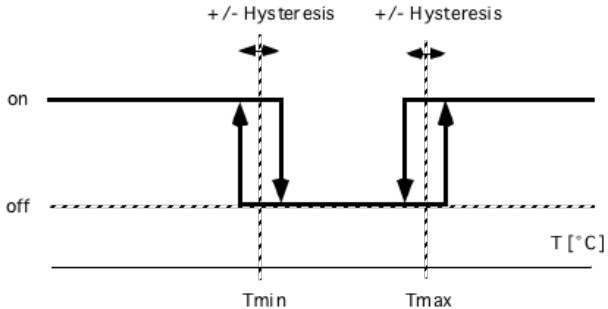
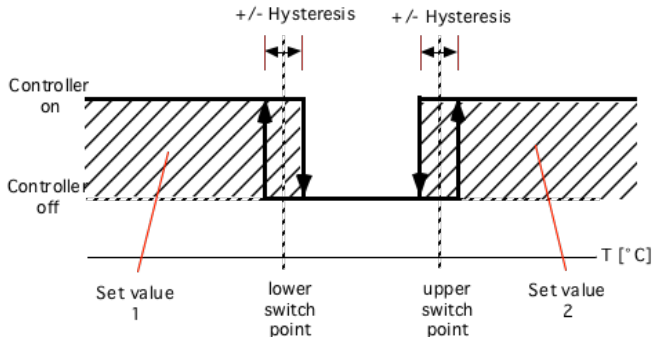
Item	Description
Warm side fan (continued)	 <p>switching of fan output as function of switch points and hysteresis</p>
Active	<p>displays state of fan output</p> <p>Note: updated only, if the option "Do temperature update - Yes" is activated</p>
<u>Dead zone function</u>	
Minimum temperature	lower switch point
Maximum temperature	upper switch point
Hysteresis	<p>hysteresis, value range: 0.0 bis 9.9</p> <ul style="list-style-type: none"> - small values will cause unnecessary frequent on / off cycles which is not recommended.
	 <p>effect of the different settings</p>
<u>Filter</u>	<p>time constant of the digital filter, also defines the sampling rate of the controller. Can be used to adapt to the timing of the open loop control system</p> <p>Note: control systems with dead time require a larger filter time constant</p>
<u>Controller</u>	
KP	Proportional coefficient of the controller, value range 0..63, typical values: 5..30
KI	Integral coefficient of the controller, value range 0..63, typical values: 1..5
KD	Derivative coefficient of the controller, value range 0..63, typical values: 5..30

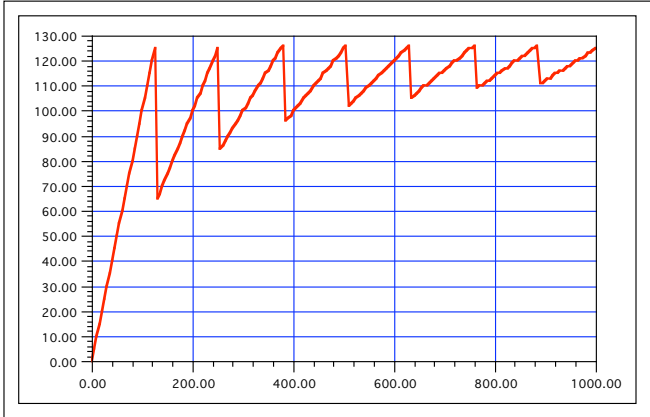
Item	Description
IL (x10)	<p>limit for the integration sum, value range 0..999, internally multiplied with 10 (range applied = 0..9999)</p> <p>the value added to the PWM value is calculated as follows:</p> $I - \text{Anteil} = \frac{I - \text{Summe}}{\left(\frac{IL}{\text{PWM-Limit}} + 1\right)}$ <p>the maximum I-Part added to the pwm value as function of IL is shown in the graph below:</p> 
PWM limit	<p>limit for the output stage, range 0..127, default value is 127 (= 100% power), a value of 0 shuts down the output stage</p>
Sensor type	selection of sensor type: pt100, pt1000 or special sensor
<u>Output</u>	
OK	the auxiliary output will be activated if the actual temperature of sensor 1 is in a range +/- "Tolerance range" around the set value
Alarm	the auxiliary output will be activated if the actual temperature of sensor 1 is outside +/- "Alarm range" around the set value
<u>Input</u>	
Turn off	the output stage will be shut off, when the auxiliary input is activated (Standard value, to make the controller functional without wiring the input)
Turn on	the output stage will be turned on, when the auxiliary input is activated

Item	Description
DUAL-Mode	with auxiliary input activated the controller works with set value 2, else with set value 1
<u>Supply voltage range</u>	
Min. .. Max..	if the supply voltage is out of this range an error is set and the controller output stage is inhibited
<u>Operation mode</u>	
Peltier-Controller	sets Operation mode to "Peltier-Controller" - polarity of output is changed for cooling / heating
Heating-Controller	sets Operation mode to "Heating-Controller" - output is pulse width modulated if actual temperature is below set value - output is off if actual temperature is above set value - Slow-PWM-Mode for solid state relay (SSR) available
<u>Information</u>	
Actual temperature 1	actual value of temperature in 1/10 °C of sensor 1 will be updated only, if the option "Do temperature update - yes" is activated, if not, the value is displayed which was valid at the last time the user clicked on the „Read“ or „Update“ button
Do temperature update	see above Note: if using the „Recorder“ function, this option must be OFF !
Actual temperature 2	actual value of temperature in 1/10 °C of sensor 2, if sensor 2 is not configured (limit = -99.9) the field is suppressed
Actual temperature 3	actual value of temperature in 1/10 °C of sensor 3, if sensor 3 is not configured (limit = -99.9) the field is suppressed
Firmware version	displays the firmware-version of TC3215-RS232 in format: nnn.mm nnn main version mm sub version
Chip temperature	temperature measured in the controller-chip in °C. <u>Note:</u> This value may differ a few degrees celsius from the real temperature inside the housing of the TC3215-RS232
<u>Error</u>	
Configuration invalid	configuration memory does not contain valid data
Stack error	(stack error) internal firmware error or interference problem
EEPROM	failure while writing the configuration to the EEPROM
Over current	overload or short circuit at the output of the TC3215-RS232
Over temperature device	the TC3215-RS232 is overheated, temperature of the environment too high or overload
Over temperature sensor 2	the actual value of sensor 2 is above the configured limit
Over temperature sensor 3	the actual value of sensor 3 is above the configured limit

Item	Description
Range error	the actual value of sensor 1 is outside the allowed range (< -75.0 oder > 175.0°C)
Range error sensor 2	the actual value of sensor 2 is outside the allowed range (< -75.0 oder > 175.0°C)
Range error sensor 3	the actual value of sensor 3 is outside the allowed range (< -75.0 oder > 175.0°C)
General	different internal failures of the TC3215-RS232
Watchdog	the program flow has been interfered, the monitoring function was activated
Under voltage	the supply voltage is below the lower limit
Over voltage	the supply voltage is beyond the upper limit

Button	Description
Close	close the dialog
Save	save values of the user interface to disk
Load	load values from disk
Read	read data from TC3215-RS232
Update	update data of the TC3215-RS232

4.4. Command line interface

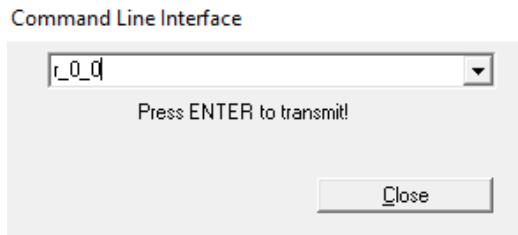

Command line interface

With this dialog „Low-Level“ commands in the form r_0_0 may be sent to the controller. The answer will be displayed in the log window if the necessary options are set. Requires in depth knowledge of the command set.

Observe Warnings given in chapter 4.1 !

4.5. Recorder

The „Recorder“ function uses a special debug mode of the TC3215-RS232. After activated, the controller sends internal values continuously until stopped. This function is a „mighty“ tool for optimizing the control loop settings.

The scale of the display will be adapted automatically. Minimum, maximum and mean value are displayed as numerical value (see vertical axes)

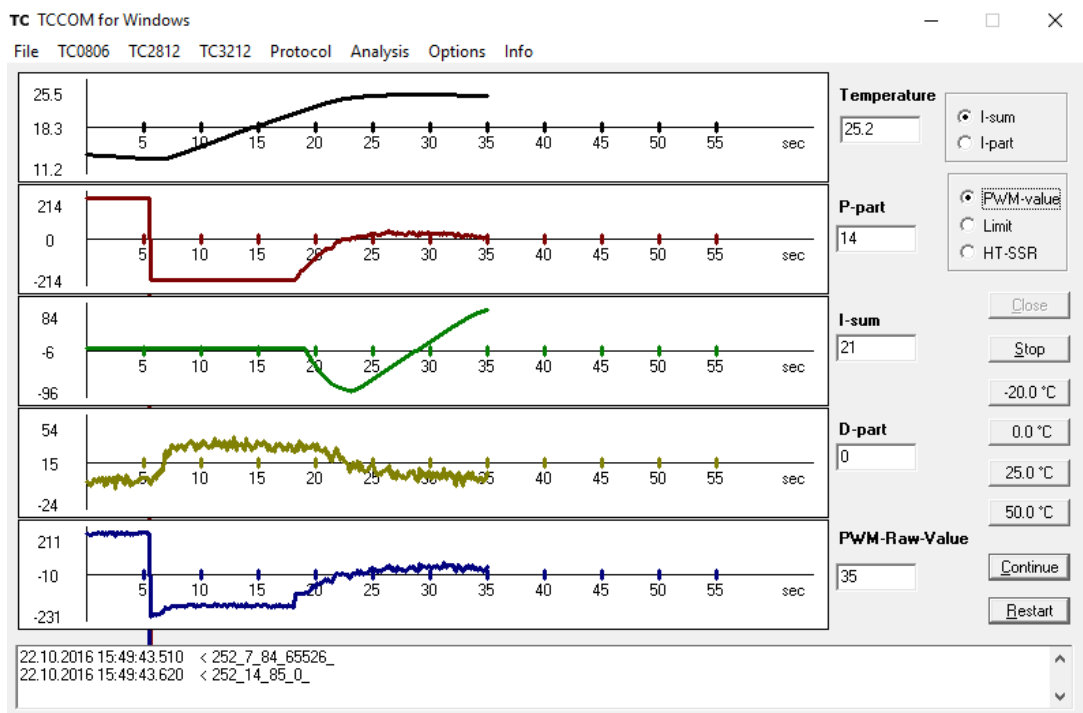

Recorder-Display

Item	Description
Temperature	actual value of the temperature in 1/10°C
P-part	Proportional part of the controller
	Note: this is a raw value which is normalized to form the control output value

Item	Description
I-part	<p>Integration sum or integral part of the controller (selectable via I-sum or I-part)</p> <p>Note: this is a raw value which is normalized to form the control output value</p>
D-part	<p>Derivative part of the controller</p> <p>Note: this is a raw value which is normalized to form the control output value</p>
PWM-Raw-Value	<p>PWM-Value, the value used to drive the output stage, range -127 ..0..+127 or +/- PWM-Limit</p> <p>Note: you can select which value is displayed:</p> <ul style="list-style-type: none">- "PWM-value" the raw value where the value may exceed the -127 ..0..+127 range of the output stage- "Limit" the limited value, which shows the effective output power- „HT-SSR" value normalized for the slow PWM mode used for driving solid state relay (SSR) , range 0..15

Button	Description
Close	closes the recorder display
Stop	stops the Recorder
-20.0 °C	set the temperature set value of the TC0806 to -20.0°C
0.0 °C	set the temperature set value of the TC0806 to 0.0°C
25.0 °C, 50.0°C	same as above
Note: the actuals values of the 4 buttons may be changed using the program settings	
Continue	<p>restarts the recorder preserving the recorded values</p> <p>Note: when stopped the values are not recorded, therefore there may be a „jump" of the values</p>
Restart	<p>clears all values and restarts the recorder</p> <p>Note: the scale will be reset and recalculated</p>

4.6. Manage configuration

4.6.1. Overview

In the normal mode solely „Read configuration“ is available. In this mode only 3 buttons are enabled, values cannot be edited.

Button	Description
Close	closes the dialog
Save	saves the configuration data to disk
Read	read configuration from TC3215-RS232

Invoking „Read configuration“ will read the actual configuration data from the TC3215-RS232 and display the values in the dialog. The data may then be stored to disk.

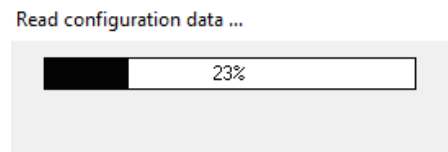

Time bar during read out

Only functional with a TC3215-RS232 attached to the serial communication line.

With expert mode enabled, see Option / General options) active, additional buttons are available:

Button (German expression)	Description
Close	close the dialog
Save	save configuration data to disk
Load	load configuration data from disk
Read	read configuration data from TC3215-RS232
Update	update configuration data of the TC3215-RS232

Invoking „Edit configuration“ will read the actual configuration data from the TC3215-RS232 and display the values in the dialog.

Invoking „Load configuration“ will open a dialog to select the file to open, then load the data from disk and display the values in the dialog.

All values except the factory settings are editable. The data may be loaded from and stored to disk. The configuration data may be read from and sent to the TC3215-RS232.

Note: read and update are only functional with a controller attached to the serial communication line.

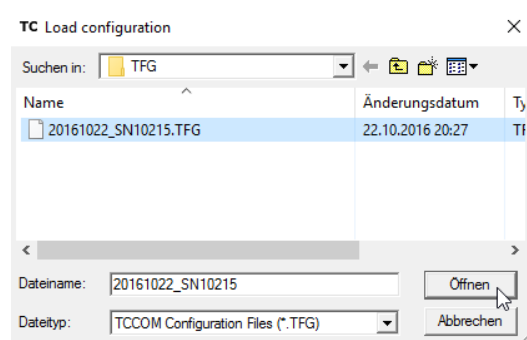

file open dialog for "Load configuration"

Observe Warnings given in chapter 4.1 !

The purpose of the different values are explained below. Because of the numerous values available they are distributed over 4 different „tabs“ with the names „General“, „Sensor 1“, „Sensor 2“, „Sensor 3“

4.6.2. Tab “General”

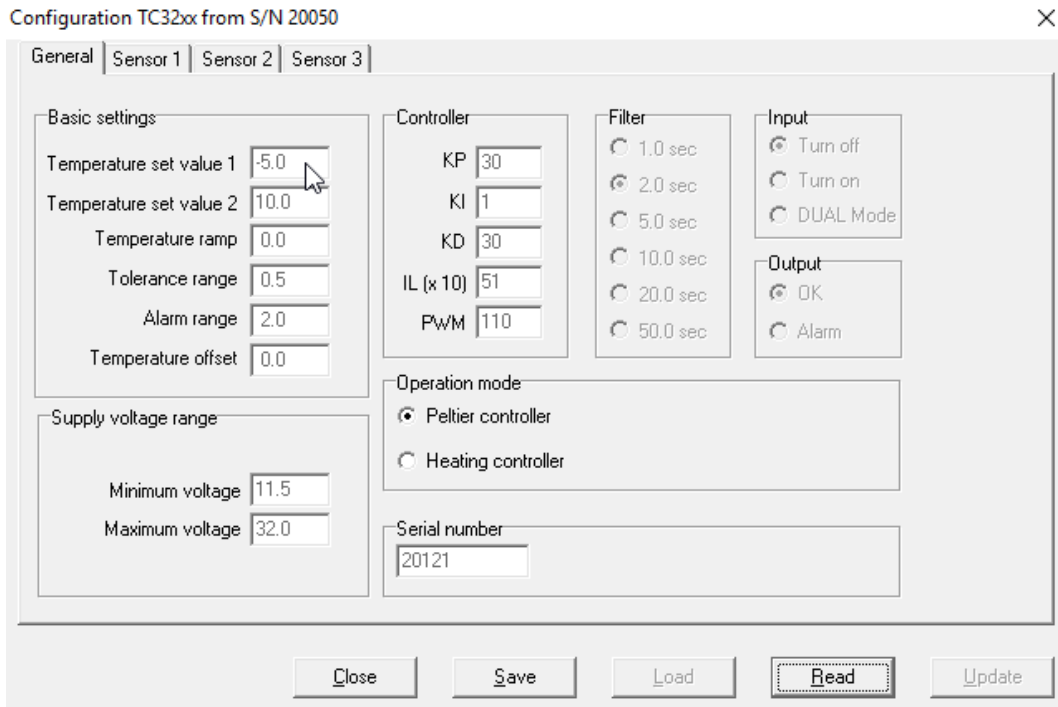

Configuration dialog – “General” = general settings (depending on the firmware-version some values may not be available)

Item	Description
<u>Basic settings</u>	
Temperature set value 1 + 2	temperature set points for the controller, range -50.0 ... + 150.0°C, sensor 1 is used for the control loop !
Temperature ramp	speed of change of the temperature set value, range 0.0 .. 9.9°C / Minute. a setting of 0.0 disables the linear ramp function
Tolerance range	defines a range around the set value in between the set value is regarded as reached. If in range: - both LED's „heating“ and „cooling“ will be shut off - the auxiliary output will be active if option „OK“ is configured
Alarm range	defines a range around the set value outside which the temperature is regarded as critical. If out of range: - LED „heating“ or „cooling“ will blink - the auxiliary output will be active if option „ALARM“ is configured
Temperature offset	value to compensate errors caused by sensor 1 itself or the system setup

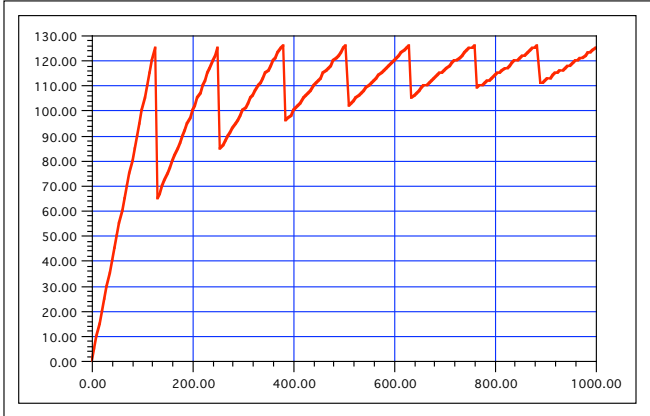
Item	Description
<u>Supply voltage range</u>	
Min. .. Max..	if the supply voltage is out of this range an error is set and the controller output stage is inhibited
<u>Controller</u>	
KP	Proportional coefficient of the controller, value range 0..63, typical values: 5..30
KI	Integral coefficient of the controller, value range 0..63, typical values: 1..5
KD	Derivative coefficient of the controller, value range 0..63, typical values: 5..30
IL (x10)	<p>limit for the integration sum, value range 0..999, internally multiplied with 10 (range applied = 0 .. 9990)</p> <p>the value added to the PWM value is calculated as follows:</p> $\mathbf{I - Anteil} = \frac{\mathbf{I - Summe}}{\left(\frac{\mathbf{IL}}{\mathbf{PWM-Limit}} + 1 \right)}$ <p>the maximum I-Part added to the pwm value as function of IL is shown in the graph below:</p> 
<p>PWM-value as function of Integration sum and applied IL-value</p> <ul style="list-style-type: none"> - using a value of 126, 253 .. has the effect, that the integral part alone can drive the output stage to 100% power - smaller value may reduce the tendency to overshoot - smaller value may also cause permanent control errors, which means that the control loop is not capable to reach the desired set point 	
PWM	limit for the output stage, range 0..127, default value is 127 (= 100% power), a value of 0 shuts down the output stage
<u>Filter</u>	<p>time constant of the digital filter, also defines the sampling rate of the controller. Can be used to adapt to the timing of the open loop control system</p> <p>Note: control systems with dead time require a larger filter time constant</p>

Item	Description
<u>Output</u>	
OK	the auxiliary output will be activated if the actual temperature of sensor 1 is in a range +/- "Tolerance range" around the set value
Alarm	the auxiliary output will be activated if the actual temperature of sensor 1 is outside +/- "Alarm range" around the set value
<u>Input</u>	
Turn off	the output stage will be shut off, when the auxiliary input is activated (Standard value, to make the controller functional without wiring the input)
Turn on	the output stage will be turned on, when the auxiliary input is activated
DUAL-Mode	with auxiliary input activated the controller works with set value 2, else with set value 1
<u>Output</u>	
OK	the auxiliary output will be activated if the actual temperature of sensor 1 is in a range +/- "Tolerance range" around the set value
Alarm	the auxiliary output will be activated if the actual temperature of sensor 1 is outside +/- "Alarm range" around the set value
<u>Operation mode</u>	
Peltier-Controller	sets Operation mode to "Peltier-Controller" - polarity of output is changed for cooling / heating
Heating-Controller	sets Operation mode to "Heating-Controller" - output is pulse width modulated if actual temperature is below set value - output is off if actual temperature is above set value - Slow-PWM-Mode for solid state relay (SSR) available
<u>Serial number</u>	serial number, for information only, not editable

4.6.3. Tab "Sensor 1"

Configuration TC32xx from S/N 20050

General | **Sensor 1** | Sensor 2 | Sensor 3

Adjustment				Factory settings			Sensor type
ADC value	pt100	pt1000	Special	pt100	pt1000	Special	<input checked="" type="radio"/> pt100
-75.0	7935	8737	8737	4	2	2	<input type="radio"/> pt1000
-50.0	11489	12049	12049	-5	-6	-6	<input type="radio"/> Special
-25.0	14996	15199	15199	-2	-2	-2	
0.0	18420	18174	18174	3	8	8	
25.0	21796	21010	21010	22819	22819	22819	
50.0	25116	23693	23693	3703	2562	2562	
75.0	28375	26272	26272	552	2798	2798	
100.0	31577	28735	28735	564	2994	2994	
125.0	34591	31024	31024	0	0	0	
150.0	37799	33337	33337	0	0	0	
175.0	40855	35496	35496				

Close Save Load Read Update

Configuration-dialog - Sensor 1

Item	Description
Adjustment	
pt100	Linearization table with values of the AD-converter for temperature steps -75.0°C bis +175.0°C for sensor type pt100 Note: Factory setting, not editable
pt1000	Linearization table with values of the AD-converter for temperature steps -75.0°C bis +175.0°C for sensor type pt1000 Note: Factory setting, not editable
Special	Linearization table with values of the AD-converter for temperature steps -75.0°C bis +175.0°C for sensor „Special“ Note: Factory setting valid for pt1000
Factory settings	
internal values	compensation of drift Note: factory setting, not editable When changing the linearization table "Special" all values must be set to zero to disable compensation of temperature drift and 3-wire-correction. These values can be determined in factory only.
Sensor-Typ	select sensor type: pt100 / pt1000 / Special („Special" selects a linearization table which can be adapted by the customer, factory default is pt1000)

4.6.4. Tab "Sensor 2"

Configuration TC32xx from S/N 20050 X

General | Sensor 1 | **Sensor 2** | Sensor 3

Adjustment		Factory settings		Dead zone settings	
	ADC value		pt1000		
-75.0	2876	PosComp	14	MinTemp	-99.9
-50.0	6177		11	MaxTemp	-99.9
-25.0	9317	NegComp	-8	Hysteresis	2.0
0.0	12303		-4		
25.0	15133	RefTemp	22819		
50.0	17799				
75.0	20377				
100.0	22849				
125.0	25135				
150.0	27444				
175.0	29597				

User settings	
Temperature limit	-99.9
Temperature offset	0.0

Configuration-dialog – Sensor 2

Item	Description
<u>Adjustment</u>	<p>Linearization table with values of the AD-converter for temperature steps -75.0°C bis +175.0°C for sensor type pt1000 / sensor 2</p> <p>Note: Factory setting, not editable</p>
<u>Factory settings</u>	<p>internal values, compensation of drift</p> <p>Note: factory setting, not editable</p>
<u>User settings</u>	
Temperature limit	<p>Temperature limit for sensor 2, range allowed: -99.9, -75.0 ... 175.0, nominal range: -50.0 ... 150.0</p> <p>A value of -99.9 disables the sensor and therefore has to be set if the sensor is absent</p> <p>if the actual temperature value exceeds the limit value the controller output stage will be shut off</p>
Temperature offset	<p>value to compensate errors caused by sensor 2 itself or the system setup</p>
<u>Dead zone function</u>	
MinTemp	lower switch point
MaxTemp	upper switch point

Item	Description
Hysteresis	hysteresis, value range: 0.0 bis 9.9 - small values will cause unnecessary frequent on / off cycles which is not recommended.

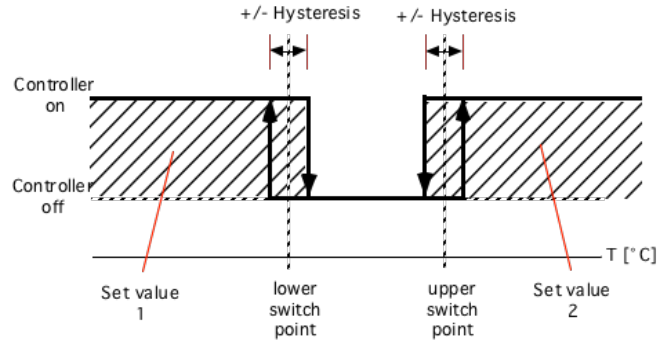

effect of the different settings

4.6.5. Tab "Sensor 3"

Configuration TC32xx from S/N 20050 ×

General | Sensor 1 | Sensor 2 | **Sensor 3**

<p>Adjustment</p> <table border="0"> <tr> <td></td> <td style="text-align: right;">ADC value</td> </tr> <tr> <td>-75.0</td> <td style="text-align: right;">2871</td> </tr> <tr> <td>-50.0</td> <td style="text-align: right;">6175</td> </tr> <tr> <td>-25.0</td> <td style="text-align: right;">9311</td> </tr> <tr> <td>0.0</td> <td style="text-align: right;">12295</td> </tr> <tr> <td>25.0</td> <td style="text-align: right;">15123</td> </tr> <tr> <td>50.0</td> <td style="text-align: right;">17791</td> </tr> <tr> <td>75.0</td> <td style="text-align: right;">20367</td> </tr> <tr> <td>100.0</td> <td style="text-align: right;">22846</td> </tr> <tr> <td>125.0</td> <td style="text-align: right;">25132</td> </tr> <tr> <td>150.0</td> <td style="text-align: right;">27438</td> </tr> <tr> <td>175.0</td> <td style="text-align: right;">29583</td> </tr> </table>		ADC value	-75.0	2871	-50.0	6175	-25.0	9311	0.0	12295	25.0	15123	50.0	17791	75.0	20367	100.0	22846	125.0	25132	150.0	27438	175.0	29583	<p>Factory settings</p> <p style="text-align: right;">pt1000</p> <p>PosComp <input type="text" value="14"/></p> <p style="margin-left: 20px;"><input type="text" value="8"/></p> <p>NegComp <input type="text" value="-5"/></p> <p style="margin-left: 20px;"><input type="text" value="-3"/></p> <p>RefTemp <input type="text" value="22819"/></p>	<p>Warm side fan</p> <p>MinTemp <input type="text" value="5.0"/></p> <p>MaxTemp <input type="text" value="35.0"/></p> <p>Hysteresis <input type="text" value="3.0"/></p> <p>Delay <input type="text" value="20"/></p>
	ADC value																									
-75.0	2871																									
-50.0	6175																									
-25.0	9311																									
0.0	12295																									
25.0	15123																									
50.0	17791																									
75.0	20367																									
100.0	22846																									
125.0	25132																									
150.0	27438																									
175.0	29583																									
<p>User settings</p> <p>Temperature limit <input type="text" value="50.0"/></p> <p>Temperature offset <input type="text" value="0.0"/></p>																										

configuration-dialog – Sensor 3

Item	Description
<u>Adjustment</u>	Linearization table with values of the AD-converter for temperature steps -75.0°C bis +175.0°C for sensor type pt1000 / sensor 2 Note: Factory setting, not editable
<u>Factory settings</u>	internal values, compensation of drift Note: factory setting, not editable

Item	Description
<u>User settings</u>	
Temperature limit	<p>Temperature limit for sensor 2, range allowed: -99.9, -75.0 ... 175.0, nominal range: -50.0 ... 150.0</p> <p>A value of -99.9 disables the sensor and therefore has to be set if the sensor is absent</p> <p>if the actual temperature value exceeds the limit value the controller output stage will be shut off</p>
Temperature offset	value to compensate errors caused by sensor 2 itself or the system setup
<u>Warm side Fan</u>	
Minimum temperature	lower switch point for the fan (T min)
Maximum temperature	upper switch point for the fan (T max)
Hysteresis	Hysteresis, explained below ..
Delay	time value, delays switching after the condition for a state change occurs

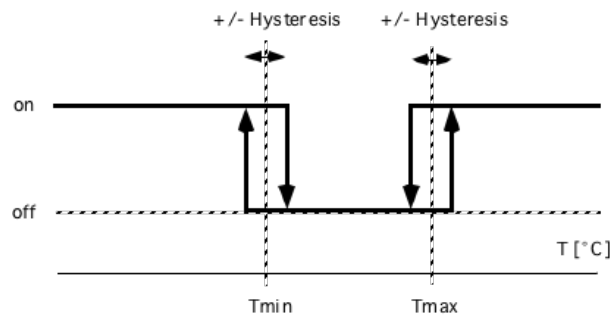

switching of fan output as function of switch points and hysteresis

5. Command set

Warning: wrong usage of the commands shown here can render the controller useless, can destroy the controller and the system attached. High temperature and high currents can occur. Danger of injuries and fire hazard.

RAM-General configuration

read/write command r .. _ / w_ .. _	Meaning	Default	value range	remarks
0	setValue_1	0	-750...1750	set value 1 (nominal range -50.0 .. 150.0 °C)
1	setValue_2	100	-750...1750	set value 2 (nominal range -50.0 .. 150.0 °C)
2	tolRange	5	+/- 99	tolerance range (0 .. +/- 9.9 °C)
3	alarmRange	20	+/- 99	alarm range (0 .. +/- 9.9 °C)
4	filter	0	0..5	index into filter table (1/2/5/10/20/50 s)
5	cfg	0	b ii oo mm ss	ii = in, oo = out, mm = operation mode, ss = sensor-select
6	KP	30	0..63	proportional coefficient
7	KI	1	0..63	Integral coefficient
8	KD	30	0..63	derivative coefficient
9	IL	26	0..999	integration-limit, internally multiplied with 10
10	pwmLimit	127	0, 1 ..127	PWM-limit
11	offset	0	-127 .. 127	Offset compensation (0 .. +/- 12.7 °C)
12	setValRamp	0	0..99	Temperature-Ramp [0.0 ..9,9°C]
13	tempLimit2	-99.9	-999, -750 .. + 1750	Temperature limit for Sensor 2
14	tempLimit3	-99.9	-999, -750 .. + 1750	Temperature limit for Sensor 3
15	offset2	0	-99 .. 99	Offset compensation for Sensor 2
16	offset3	0	-99 .. 99	Offset compensation for Sensor 2
17	kkTempMin	50	-750 .. + 1750	min. temperature heat sink [0.1°C]
18	kkTempMax	300	-750 .. + 1750	max. temperature heat sink [0.1°C]
19	kkTempHyst	0	0..99	hysteresis in 0.1 °C
20	kkDelay	20	1..127	delay fan switching [250ms]
21	tcMinVolt	115	115..290	lower limit supply voltage
22	tcMaxVolt	290	115..290	upper limit supply voltage
23	dzTempMin	50	-750 .. + 1750	lower limit dead zone function [0.1°C]
24	dzTempMax	300	-750 .. + 1750	upper limit dead zone function [0.1°C]
25	dzTempHyst	20	0..99	hysteresis dead zone function [0.1°C]

EEPROM-General configuration

read/write command r .. _ / w_ .. _	Meaning	Default	value range	remarks
300	setValue_1	0	-750...1750	set value 1 (nominal range -50.0 .. 150.0 °C)
301	setValue_2	100	-750...1750	set value 2 (nominal range -50.0 .. 150.0 °C)
302	tolRange	5	+/- 99	tolerance range (0 .. +/- 9.9 °C)
303	alarmRange	20	+/- 99	alarm range (0 .. +/- 9.9 °C)
304	filter	0	0..5	index into filter table (1/2/5/10/20/50 s)
305	cfg	0	b ii oo mm ss	ii = in, oo = out, mm = operation mode, ss = sensor-select
306	KP	30	0..63	proportional coefficient
307	KI	1	0..63	Integral coefficient

read/write command r .. _ / w_ .. _	Meaning	Default	value range	remarks
308	KD	30	0..63	derivative coefficient
309	IL	26	0..999	integration-limit, internally multiplied with 10
310	pwmLimit	127	0, 1 ..127	PWM-limit
311	offset	0	-127 .. 127	Offset compensation (0 .. +/- 12.7 °C)
312	setValRamp	0	0..99	Temperature-Ramp [0.0 ..9,9°C]
313	tempLimit2	-99.9	-999, -750 .. + 1750	Temperature limit for Sensor 2
314	tempLimit3	-99.9	-999, -750 .. + 1750	Temperature limit for Sensor 3
315	offset2	0	-99 .. 99	Offset compensation for Sensor 2
316	offset3	0	-99 .. 99	Offset compensation for Sensor 2
317	kkTempMin	50	-750 .. + 1750	min. temperature heat sink [0.1°C]
318	kkTempMax	300	-750 .. + 1750	max. temperature heat sink [0.1°C]
319	kkTempHyst	0	0..99	hysteresis in 0.1 °C
320	kkDelay	20	1..127	delay fan switching [250ms]
321	tcMinVolt	115	115..290	lower limit supply voltage
322	tcMaxVolt	290	115..290	upper limit supply voltage
323	dzTempMin	50	-750 .. + 1750	lower limit dead zone function [0.1°C]
324	dzTempMax	300	-750 .. + 1750	upper limit dead zone function [0.1°C]
325	dzTempHyst	20	0..99	hysteresis dead zone function [0.1°C]

Requests and maintenance commands

Read / Write Command r .. _ / w_ .. _	Meaning	Default	Values	Remarks
103	P-part	read only		control result
104	I-part	read only		control result
105	D-part	read only		control result
106	FW-Version	read only	100.00 .. 320.99	100 .. 320 main version, 00..99 Subversion
120	actual value Sensor 1		read only	-750..1750 0.1°C
121	actual value Sensor 2		read only	-750..1750 0.1°C
122	actual value Sensor 3		read only	-750..1750 0.1°C
150	testPWM		0..127	set constant pwm value for output stage > no control calculation
151	testMinTemp		-750..1750	lower temperature limit for test with constant PWM
151	testMaxTemp		-750..1750	upper temperature limit for test with constant PWM

Warning: wrong use of commands 150..152 will destroy controller and system and may cause overheating and fire hazard. Use solely at users own risk !

200	CmdGetDeviceType	read only	get device type
201	CmdGetDeviceState	read only	get device state
202	CmdGetErrorState	read only	get error state

Read commands have a parameter value of 0, for write commands the desired value has to be appended.

Another warning: Only the commands released for end users are documented. Using other command codes may damage the controller and is strictly forbidden!

Meaning of the structure information

RAM	interne configuration data structure, only valid until next power off
EEData	same values a cfgTeble, but stored permanently in nonvolatile memory. These values will be reloaded at next power on.

Attention:

Excessive writing to the EEData can cause a wear out of the component and result in data loss.

Values from EEData must be transferred to RAM with the command u_0_0 to be effective !

6. Configuration values

minimum value	maximum value	reset value	default value	description
-75.0	175.0	0.0	0.0	set value 1
-75.0	175.0	0.0	0.0	set value 2
0.0	9.9	0.0	0.5	tolerance range
0.0	9.9	0.0	2.0	alarm range
1	50	1	2	filter time constant
0	63	0	30	KP
0	63	0	1	KI
0	63	0	30	KD
0	999	0	25	IL (internal value *10, default 25 yields 250)
0	127	0	127	PWM-Limit
-9.9	9.9	0.0	0.0	Offset, Sensor1
0.0	9.9	0.0	0.0	temperature ramp
-99.9	175.0	0.0	-99.9	TempLimit2 (cold side)
-99.9	175.0	0.0	-99.9	TempLimit3 (warm side)
-9.9	9.9	0.0	0.0	Offset, Sensor2
-9.9	9.9	0.0	0.0	Offset, Sensor3
-75.0	175.0	0.0	5.0	fan, lower limit
-75.0	175.0	0.0	35.0	fan, lower limit
0.0	9.9	0.0	3.0	fan, hysteresis
1.0	127.0	1.0	20.0	fan delay time
1.0	31.5	1.0	11.5	supply voltage, lower limit
1.5	32.0	1.5	32.0	supply voltage, upper limit
-50.0	150.0	0.0	-99.9	dead zone, lower limit
-50.0	150.0	0.0	-99.9	dead zone, upper limit
0.0	9.9	0.0	2.0	dead zone, hysteresis

Values allowed

Description

Sn0 .. Sn2 (= Pt100 / pt1000 / Special)	sensor type
On / Off / DUAL	auxiliary input
Alarm / Good	auxiliary output
PEL / HEA	controller-mode: Peltier / Heating-Controller

7. State codes

answer to request CmdGetDeviceState (r_202_0), shown as binary values

State value	Meaning
0000 0000 0000 000X	0: auxiliary output active 1: auxiliary output not active
0000 0000 0000 00X0	0: auxiliary input active 1: auxiliary input inactive
0000 0000 0000 0X00	0: fan off 1: fan on
0000 0000 0000 1000	dead zone function: value of sensor 2 below lower limit
0000 0000 0001 0000	dead zone function: value of sensor 2 in dead zone
0000 0000 0010 0000	dead zone function: value of sensor 2 above upper limit

8. Error codes

answer to request CmdGetErrorState (r_203_0), shown as binary values

State value	Meaning
0000 0000 0000 0001	range error, Sensor 1
0000 0000 0000 0010	general error
0000 0000 0000 0100	EEPROM write error
0000 0000 0000 1000	over current
0000 0000 0001 0000	over temperature, controller
0000 0000 0010 0000	over temperature, Sensor 2
0000 0000 0100 0000	over temperature, Sensor 3
0000 0000 1000 0000	range error, Sensor 2
0000 0001 0000 0000	range error, Sensor 3
0000 0010 0000 0000	Watchdog
0000 0100 0000 0000	over voltage
0000 1000 0000 0000	under voltage
0001 0000 0000 0000	not implemented
0010 0000 0000 0000	permanently overheated
0100 0000 0000 0000	configuration invalid
1000 0000 0000 0000	Stack error

9. Sensor-Table

The sensor tables show the nominal value of the sensor and the resulting voltage, current and power values calculated for ideal conditions (without tolerances). The real values may differ.

Sensor pt100 is fed via a resistor of 1825 Ohm with a supply of 3.3V

Temperature [°C]	Sensor value [Ohm]	sensor voltage [V]	sensor current [mA]	sensor power [mW]
-75.0	70.332	0.1225	1.7411	0.2132
-50.0	80.306	0.1391	1.7320	0.2409
-25.0	90.192	0.1554	1.7231	0.2678
0.0	100.000	0.1714	1.7143	0.2939
25.0	109.735	0.1872	1.7057	0.3192
50.0	119.397	0.2026	1.6972	0.3439
75.0	128.987	0.2178	1.6889	0.3679
100.0	128.505	0.2171	1.6893	0.3667
125.0	144.182	0.2416	1.6758	0.4049
150.0	157.325	0.2619	1.6647	0.4360
175.0	166.627	0.2761	1.6569	0.4575

Sensor pt1000 is fed via a resistor of 3650 Ohm with a supply of 3.3V.
(this also applies when using the "Special" sensor selection)

Temperature [°C]	Sensor value [Ohm]	sensor voltage [V]	sensor current [mA]	sensor power [mW]
-75.0	703.320	0.5331	0.7580	0.4041
-50.0	803.063	0.5951	0.7411	0.4410
-25.0	901.923	0.6539	0.7250	0.4740
0.0	1'000.000	0.7097	0.7097	0.5036
25.0	1'097.350	0.7628	0.6951	0.5302
50.0	1'193.970	0.8134	0.6813	0.5541
75.0	1'289.870	0.8617	0.6680	0.5756
100.0	1'285.050	0.8593	0.6687	0.5746
125.0	1'441.820	0.9344	0.6481	0.6056
150.0	1'573.250	0.9940	0.6318	0.6280
175.0	1'666.270	1.0343	0.6207	0.6420